

70ZW-2

WHEEL LOADER

Direct-injection, turbocharged 118kW(158hp) engine
Operating weight 13ton, Bucket capacity 2.0-3.0m³
Strong and robust main structures
Tough and proven hydraulic components
Productive and dependable performance



T ***THE ADVANCED TRADITION***
SIMPLE
DURABLE
DEPENDABLE





The outstanding performance of Kawasaki wheel loaders has been proven all over the world.

Continuous improvement in quality since its release in 1994, the ZIV-2 wheel loaders offer long service life and outstanding productivity.

Kawasaki, a major Japanese manufacturer of wheel loaders for over half of a century combines innovative technologies and real world experience to produce the finest wheel loader in the industry.

Simple and straight forward, Kawasaki eliminates excessive functions to enhance productivity, durability, reliability, and lower operating costs.

Overall simple design makes maintenance easier and reduces costs.

Kawasaki focuses on simple, minimized electronic designs to offer the highest reliability and the easiest maintenance with minimum down time.

"Kawasaki Made" major components such as the transmission, axle and hydraulic valve are developed and manufactured by experienced personnel that concentrate their knowledge and technologies to produce the best components for Kawasaki wheel loaders.

SOPHISTICATED PERFORMANCE

JAPANESE ENGINE WITH MECHANICAL GOVERNOR

Japanese engines provide a high quality source of power. Time-proven, high quality mechanical engine governor minimizes maintenance requirements. Compared with electronic controlled high pressure fuel injection system, a wide range of fuel and engine oil can be used. The engine does not require any special diagnostic equipment or computer for service.

*For the range of fuel, please consult your local Kawasaki dealer.



TPD

Standard Torque Proportioning Differentials (TPD) improve traction in slippery conditions.



LSD (OPT)

For applications with extreme traction requirements, the optional Limited Slip Differential (LSD) provides additional traction capability.

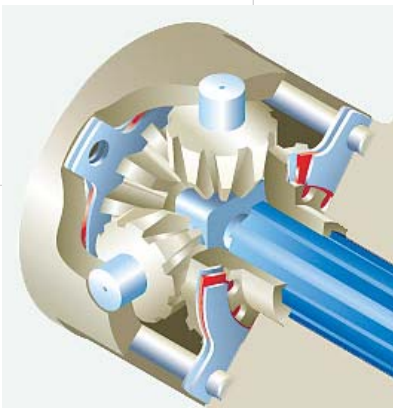

CENTER PIN

Kawasaki center pin design is rugged and durable, providing thousands of hours of trouble free operation. The spherical bearing mounted on the lower center pin area absorbs heavy stresses caused by digging.

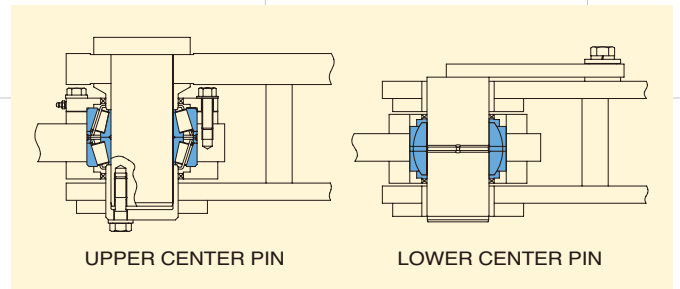

LOAD SENSING HYDRAULIC SYSTEM FOR STEERING LINE

An energy efficient design of the hydraulic system provides for steering flow to supplement the main circuit once steering demand is met. This allows for full utilization of the pump capacity for efficient operation in all conditions.

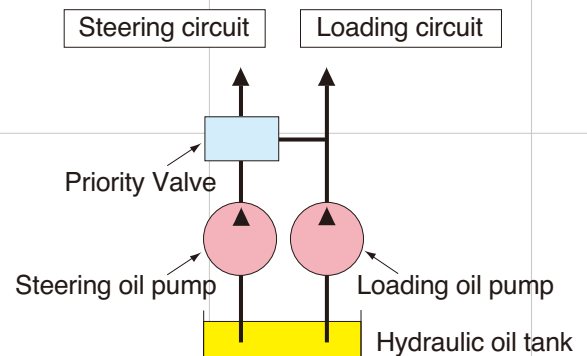

WET DISC BRAKE

Outboard mounted wet disc service brake can minimize maintenance time since the brakes are accessible without removing the axle.



DOUBLE-ELEMENT AIR CLEANER

The double-element air cleaner filters the outside air to supply clean air for the engine. Accumulated dust is automatically discharged through valves when the engine stops.

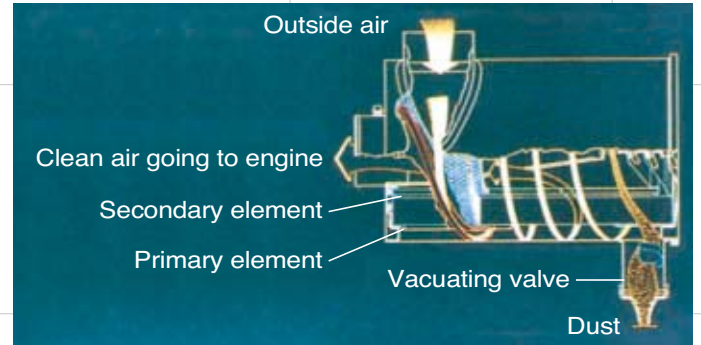

PARKING BRAKE

The parking brake is a spring-applied, air pressure-released, drum type. Based on this proven design, parking brake maintenance and adjustment can be easily done.



TRANSMISSION

Fewer parts and the simple structure of the counter shaft transmission minimizes maintenance time and cost. Transmission control can be done by using simple, twist grip, single lever which helps an operator to focus on bucket operation.

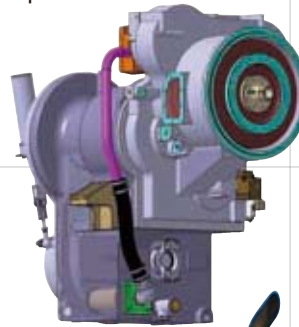

BEST OF BOTH WORLDS, PRODUCTIVE AND DEPENDABLE

HOIST ARM & BUCKET

With strong and robust hoist arms and linkage, Kawasaki loaders perform well in a wide variety of applications. High breakout force and excellent bucket rollback mean bigger loads and better load retention. Buckets are designed for easy loading and are equipped with bolt-on cutting edges or teeth for easy changing. The bucket leveler and boom kickout are standard.



SEALED BUCKET HINGE PIN

The special seal in the bucket hinge pin provides excellent sealing and grease retention which extends pin life.

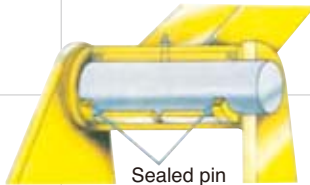

FULL BOX FRAME CHASSIS

Full box section frame is the strongest in the industry and resists twisting loads better than plate frames.



BUFFER RINGS IN HYDRAULIC CYLINDER

The hydraulic cylinders utilize a buffer ring to improve sealing capability to reduce leakage.

RIDE CONTROL (OPT)

Ride Control provides stable load handling during load and carry operation. It reduces bouncing of the equipment while traveling, improves safety, productivity and operator comfort. The system comes with speed sensitive, automatic on/off feature.

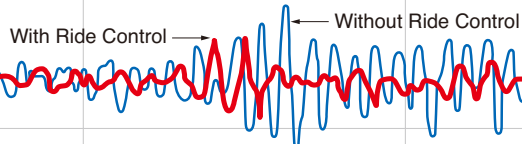
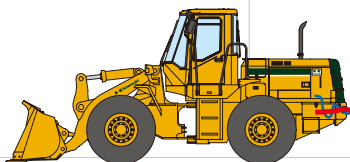

HYDRAULIC GEAR PUMP

A proven gear pump is the heart of the hydraulic system. The durable and dependable design of this gear pump provides excellent performance. Gear pumps are dirt-tolerant and heat resistant even under extremely tough job conditions. Its simple structure makes maintenance cost low.



INCREASED GREASING INTERVALS FOR UNIVERSAL JOINTS

Sealed universal joints only require greasing every 12000hours. This reduces maintenance costs significantly and provides greater durability.



EASY ACCESS SIMPLIFIES SERVICING

EASY MAINTENANCE FOR COOLING SYSTEM

A radiator sub-tank is installed in the cooling system to automatically replenish the water in the radiator. It is easy to check the water level and maintain the water supply.



SIMPLE & EFFICIENT, ONE-TOUCH OPEN-TOP RADIATOR GRILLE

To facilitate cleaning the radiator, the radiator grille swings open with pneumatic support gas springs.



EASY-ACCESS GREASING POINTS AND ENGINE OIL DRAIN PLUGS

All greasing points are easily accessible from the ground, and the engine oil drain plugs are located at the lower side of the chassis so they can be opened and closed easily.



HIGH QUALITY FINISH PAINT FOR SHEET METAL PARTS

Kawasaki's state-of-the-art painting process utilizes ED (Electro-Deposition) primer, a baked Melamine Alkyd finish coat as well as a fluororic super protection coat for a durable and attractive finish.

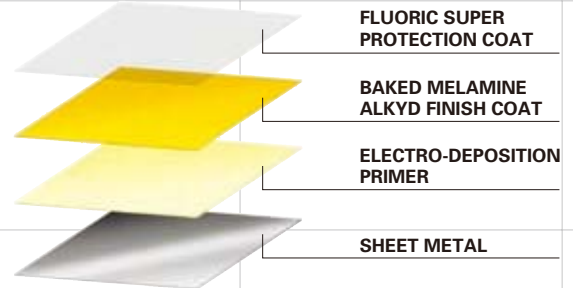

LADDERS ON BOTH SIDE

Ladders on both sides of the machine allow for easy access to the operator area. Steps and hand rails are located for safe access.



HALOGEN HEAD LAMPS (OPT)

Front and rear working lights are bright, halogen lamps for improved safety and visibility.



LED REAR LAMPS (OPT)

Long life, LED (Light-Emitting Diode) lamps are available as an option for the rear tail lights. These lights are very bright and durable.

T **THE COMFORT ZONE** **"NO OTHER PLACE LIKE THIS CAB"**

CAB (OPT)

The "walk-through" CAB utilizes curved glasses for front and rear windshields to provide excellent visibility. The front and rear glass is mounted in rubber gaskets that make windshield replacement fast and easy.



ROPS/FOPS CAPABILITY (OPT)

The operator's cab is fully certified to meet ROPS (Rollover Protective Structure) and FOPS (Falling Object Protective Structure) regulations.



AIR CONDITIONER (OPT)

The air conditioner keeps the operator comfortable in a wide range of climates.

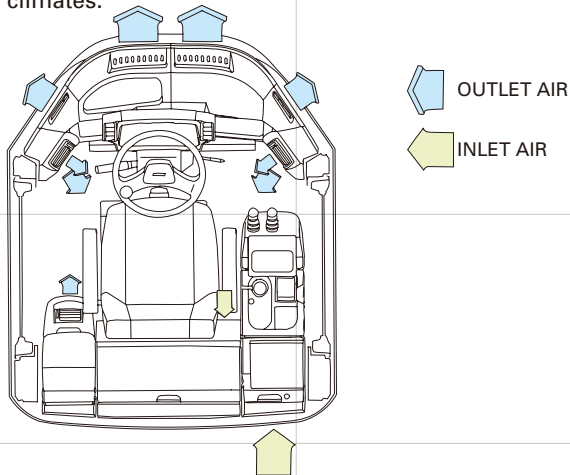

OPERATING SEAT

The 70ZIV-2 provides many operator comfort features. The seat with armrests is fully adjustable for height, position and suspension. The ergonomic design incorporates critical balances between seat location and visual position, steering wheel, pedals and levers to make the machine easy to operate.





AT-A-GLANCE METERS AND GAUGES

The exact conditions of the machine can be instantly checked from the gauges and indicator lights on the instrument panel; speedometer, engine water temp. gauge, transmission oil temp. gauge, fuel indicator, air pressure gauge, engine hour meter, and various other warning and indicator lights.



VISCOUS MOUNT

Viscous mounting of the cab effectively reduces noise and vibration that provides greater comfort for an operator.

TILT STEERING

The tilt steering column adjusts to fit a variety of operator needs and offers greater comfort and efficiency.

DOWNSHIFT BUTTON

The downshift button located on the boom control lever provides for quick, convenient downshifting from 2nd gear to 1st gear.

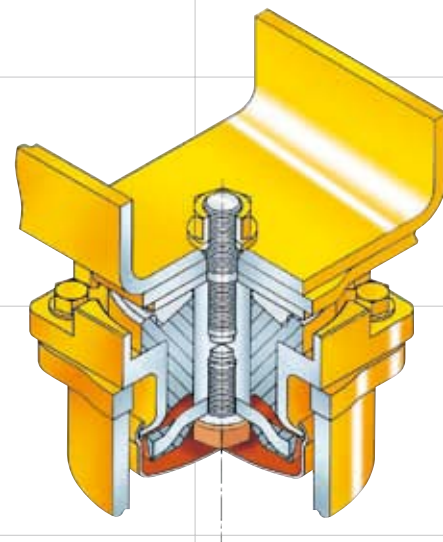

BOOM AND BUCKET CONTROL LEVERS

The pilot operated hydraulic control levers with wrist rest give the operator better control. Downtime can be minimized, thanks to the simplified mechanical structure.

OPERATING SPECIFICATIONS

Engine

Make & model	ISUZU "A-6BG1T" diesel engine
Type	4-cycle, water-cooled, direct injection, with turbocharged
Rated power	Gross 122kW (164 hp)/2,200rpm Net 118kW (158 hp)/2,200rpm
Maximum torque	Gross 569N·m (58kgf·m)/1,800rpm Net 559N·m (57kgf·m)/1,800rpm
Number of cylinders (bore × stroke)	6 105mm×125mm
Total displacement	6.49lit
Cooling type	Direct drive pusher type fan Pressurized radiator
Fuel injection pump	Bosch type
Governor	All-speed mechanical type
Air cleaner	Dry type (Double element)
Generator	AC 24V 0.96 kW (40 ampere)
Starter motor	DC 24V 4.5 kW (6.0 hp)
Batteries	DC 12V 88 Ah × 2

Torque converter & Transmission

Torque converter	Make	Kawasaki	
	Type Stall torque ratio	3-element, 1-stage, 1-phase 3.40	
Transmission	Make	Kawasaki, Full power shift	
	Type Clutch type	Countershaft type Wet hydraulic, multi disc	
Traveling speed		Forward	Reverse
	1st	7.5km/h	7.5km/h
	2nd	12.5km/h	12.5km/h
	3rd	20.5km/h	20.5km/h
	4th	37.0km/h	37.0km/h
Reduction gear ratio		Forward	Reverse
	1st	4.272	4.286
	2nd	2.513	2.521
	3rd	1.442	1.446
	4th	0.676	0.678

Axles & Final drives

Type	4-wheel drive
Axle make & type	Kawasaki Full floating type
Differential gear	Spiral bevel gear, torque proportioning, gear ratio 3.90
Final reduction gear	Outboard mounted, planetary gear, gear ratio 5.333
Rear axle oscillation angle	±12°
Tire (standard)	20.5 (L2) Tubeless
Wheel rim	17.00×25

Weight change

Option item	Operating weight(kg)	Tipping load(kg)		Overall width(mm) (outside tire)	Tread	Vertical dimensions (mm)	Overall length(mm)
		Straight	Full turn				
Canopy(instead of ROPS cab)	-450	-425	-365	—	—	-65	—
Soft cab(instead of ROPS cab)	-170	-205	-175	—	—	±0	—
ROPS canopy(instead of ROPS cab)	-200	-150	-140	—	—	±0	—
Remove ROPS cab	-520	-490	-420	—	—	-275	—
Tires	20.5-25-12PR(L2)	±0	±0	±0	±0	±0	—
	20.5-25-12PR(L3)	+120	+90	+80	±0	±0	—
	20.5-25-16PR(L3)	+160	+120	+105	±0	±0	—
	23.5-25-12PR(L2)	+730	+560	+480	+50	-40	+60
Air conditioner	+100	+120	+100	—	—	—	—
Counter weight	+330	+740	+630	—	—	—	+65
Belly guard	+55	+50	+40	—	—	—	—

Brake system

Service brake	4-wheel hydraulic wet-disc brakes actuated by air Dual circuits
Parking brake	Spring applied air pressure released type located on front driveline
Emergency brake	Same as parking, applied on failure in brake air line

Steering system

Type	Articulated frame, hydraulic power steering by Orbitrol
Full articulation angle	40° to each side

Loading system

Type	Front end loading, Z bar linkage system	
Bucket dumping angle at fully raised	45°	
Hydraulic cycle time	Lifting (at full load)	6.2sec
	Lowering (empty)	3.1sec
	Dumping	1.2sec
	Total cycle time	9.5sec





Hydraulic system

Oil pump	Steering oil pump	Gear type, 151lit/min 6.9Mpa (70kgf/cm ²) @2,200rpm
	Main oil pump	Gear type, 60lit/min, 6.9Mpa (70kgf/cm ²) @2,200rpm
	Pilot oil pump	Gear type, 41lit/min, 3.5Mpa (36kgf/cm ²) @2,200rpm
Control valve	Loading	Multiple control valve
	Steering	Orbitrol
Lift cylinder	Type	Double acting piston
	Number × bore × stroke	2×140mm×754mm
Tilt cylinder	Type	Double acting piston
	Number × bore × stroke	1×160mm×502mm
Steering cylinder	Type	Double acting piston
	Number × bore × stroke	2×80mm×380mm
Relief set pressure	Control valve	20.6Mpa (210kgf/cm ²)
	Priority valve	20.6Mpa (210kgf/cm ²)

Service refill

Fuel tank	220lit
Engine lubricant (including oil pan)	22lit
Engine cooling water	35lit
T/M&T/C	30lit
Axle front/rear	99lit
Brake equipment	4.9lit
Hydraulic system (including oil tank)	135lit

Bucket

		Standard boom					
		General purpose(Stock pile)		General purpose(Loose material)		Rock Straight-edge	
		Bolt-on edges	Teeth	Bolt-on edges	Teeth	Teeth	
		GSC	GST	LSC	LST	RST	
							
Bucket capacity	heaped	m ³	2.7	2.5	3.0	2.8	2.0
	struck	m ³	2.3	2.2	2.6	2.4	1.7
Max. dumping clearance		a mm	2,705	2,615	2,635	2,545	2,640
Max. dumping reach		b mm	1,115	1,180	1,190	1,250	1,145
Digging depth (with bucket level)		c mm	115	130	115	130	135
Breakout force		kN	123	134	113	122	140
		kgf	12,500	13,700	11,490	12,490	14,300
Overall length		d mm	7,390	7,515	7,495	7,615	7,480
Overall height	bucket full raise	e mm	5,130		5,235		4,920
Overall width	outside bucket	f mm	2,670	2,680	2,670	2,680	2,680
Min. turning radius at outside bucket (bucket carry position)		g mm	6,040	6,070	6,065	6,105	6,065
Operating weight	with ROPS CAB	kg	12,920	12,830	13,010	12,920	13,050
Static tipping load	straight	kg	9,840	9,950	9,750	9,890	9,770
	full turn	kg	8,440	8,530	8,350	8,470	8,400

The weight and load figure includes 20.5 (L2) tubeless tire, ROPS cab, lubricant, coolant, full fuel tank and operator.

Bucket selection charts

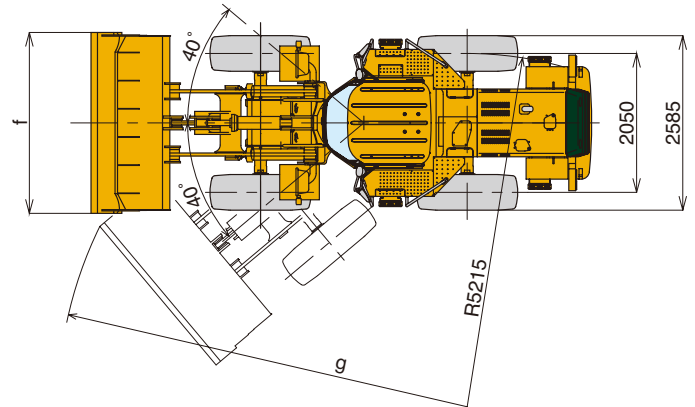
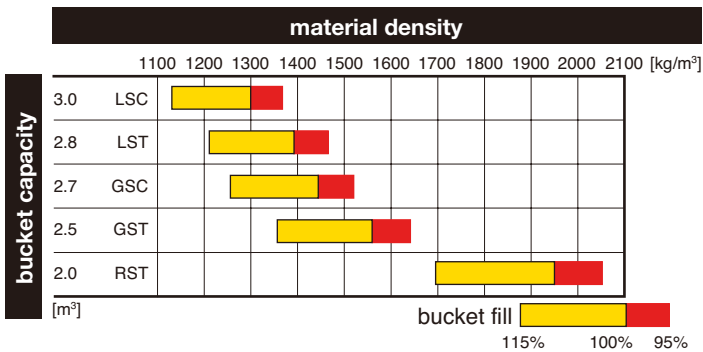

Material density

Approx. material weights per cubic meter

Basalt, granite, piled	1537 kg/m ³
Clay and gravel, dry	1601 kg/m ³
Earth, mud, wet	1729 kg/m ³
Granite, broken	1537 kg/m ³
Gravel	1761 kg/m ³
Gypsum	2268 kg/m ³
Limestone, coarse, sized	1569 kg/m ³
Sand, dry	1681 kg/m ³
Sandstone, quarried	1313 kg/m ³
Stone or gravel. 3/4" size	1569 kg/m ³

Remarks

- * Materials and specifications are subject to change without notice and without any obligation on the part of the manufacturer.
- * This information, while believed to be completely reliable, is not to be taken as warranty for which we assume legal responsibility.
- * Dumping clearance and reach are measured from bucket edge in accordance with SAE J732C.
- * Color for model shown in this brochure is a standard Kawasaki yellow.
- * Counterweight(option) should not be used with tire ballast.
- * This specification sheet may contain attachments and optional equipment which are not available in your area. Please contact your local Kawasaki dealer for those items which your require.

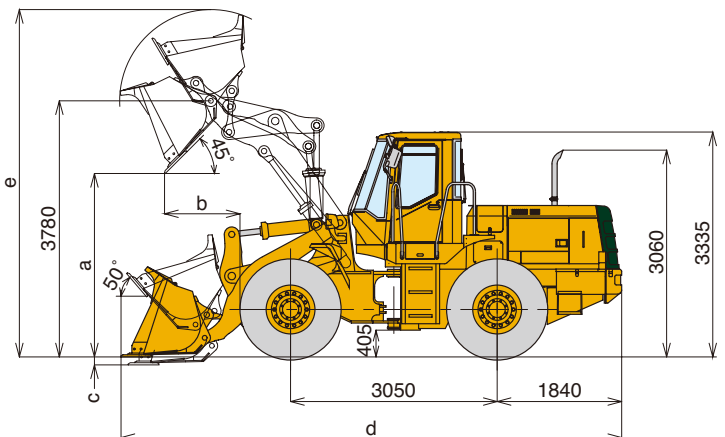

Equipped with GSC bucket, 20.5 (L2) tubeless tire and ROPS cab.

70ZV-2

STANDARD EQUIPMENT

*Standard specifications may vary. Please consult your Kawasaki dealer for more information.

Electrical

40 ampere alternator
Back up lights
Brake & tail lights
Electric starter
Headlights with high and low beams (4 front)
Transmission declutch switch
Turn signal switch
Working lights (2 rear)

Gauges and indicators

Air cleaner warning lamp
Air pressure gauge and warning lamp
Auto shift indicator lamp
Battery charge lamp
Brake oil circuit warning lamp
Central warning lamp
Engine coolant temperature gauge and warning lamp
Engine oil pressure warning lamp
Fuel level gauge
High beam indicator lamp
Hour meter

Neutral indicator lamp
Parking brake indicator lamp
Preheat indicator lamp
Rear working light indicator lamp
Speedometer
Torque converter oil temperature gauge and warning lamp
Transmission control warning lamp
Transmission declutch lamp
Transmission status monitor
Turn signal indicator lamp (right/left)

Operator environment

Ashtray
Adjustable operator seat with suspension
Boom/bucket control dual levers
Cigarette lighter (24V)
Down shift button
Electric dual horn
Tilt steering wheel
Wrist rest

Power train

Air cleaner double elements dry type
Air over hydraulic enclosed wet multi-disc brakes
Kawasaki auto shift transmission
Kawasaki axles, torque proportioning differentials (front/rear)
Kawasaki torque converter
ISUZU A-6BG1T diesel engine
Tires, 20.5(L2) tubeless

Others

Bucket leveler
Drawbar hitch with pin
Handrails
Kickout device
Ladders, left and right
Loading linkage, sealed Z-bar type
Secondary brake

OPTIONAL ITEMS

Air conditioner
Air suspension seat
Additional counterweight
Back up alarm
Emergency steering
Engine and Transmission belly guard
High lift arm
Hydraulic three spool valve system
LED rear lamps
Limited slip differential (LSD) for both axles
Log handling package
Open canopy
Open ROPS/FOPS canopy
Pre cleaner
Quick coupler and hydraulic circuit for quick coupler pins
Rear wiper and washer
Ride control (speed sensitive automatic)
ROPS/FOPS cab (left and right doors, walk-through design)
Seat belt
Several bucket and tire options are available
Soft cab (left and right doors, walk-through design)
Vandalism protection kit
Working lights (2 front)

Cab specifications

Coat hook
Cup holder
Floor mat
Front wiper and washer
Lockable doors with sliding windows by regulator handles (left and right)
Rearview mirrors (interior and exterior)
Storage compartment
Sun visor
Tinted safety glass



Designed and Manufactured by Kawasaki

